

Notes:
Do not polish inside of cover

REV.	REVISIONS	DATE	APPROVED

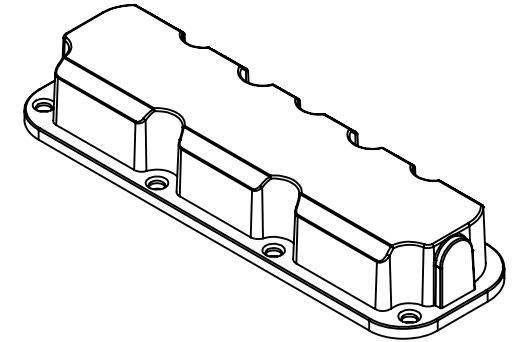

SECTION D-D
SCALE 1 : 2

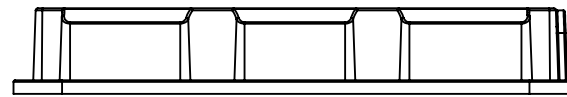
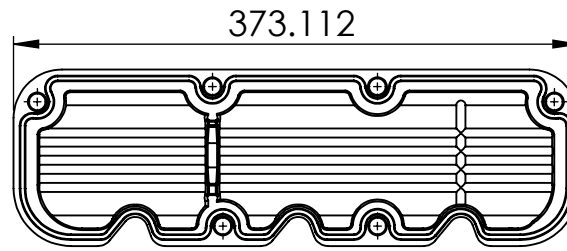
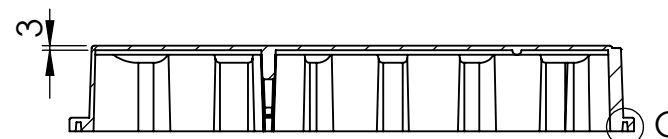
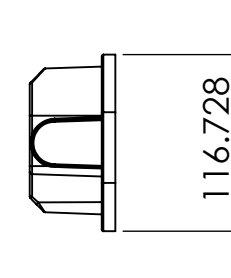
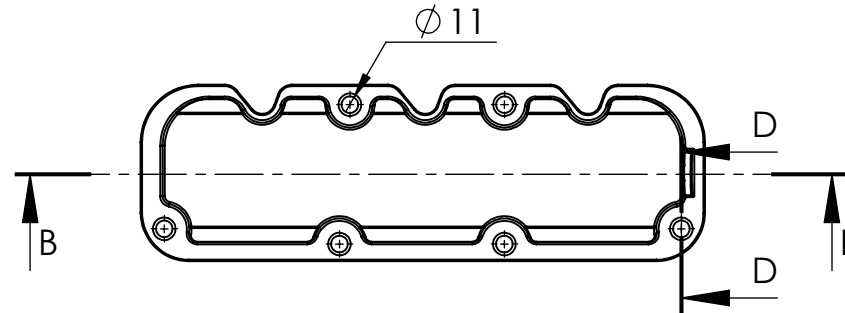
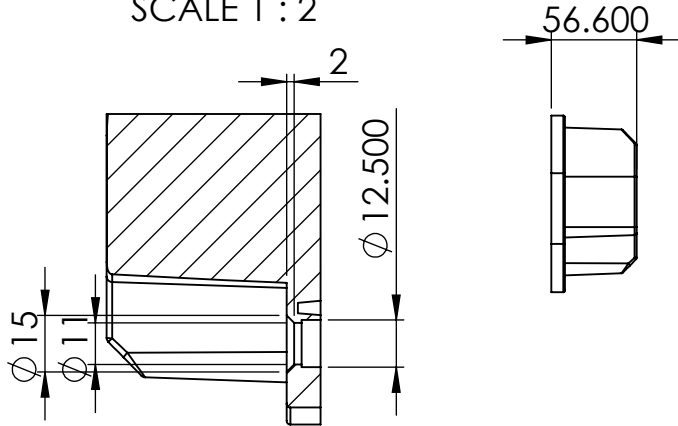

SECTION B-B

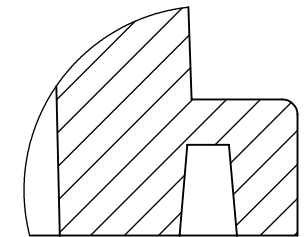

DETAIL C
SCALE 2 : 1

DRAWING NO.: L67CV2d

This model is the mirror image of model L67CV1d with the exception of the oil fill hole.

When placing both covers side by side with the side grooves facing each other, cylinder extrusions must be on the same side.

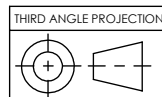

PROPRIETARY AND CONFIDENTIAL

MATERIAL	ALUMINIUM
ROUGHNESS	0.8
FINISH	POLISHED
DO NOT SCALE DRAWING	

NAME	DATE
DRAWN A.KAD	28/12/12
CHECKED ----	----
COMMENTS:	
DIMENSIONS ARE IN mm TOLERANCES: DECIMAL ± 0.1mm ANGULAR ± 1°	

SIZE	DWG. NO.	REV.
A4	L67CV2d	
SCALE: 1:5	AS1100-1992	SHEET 1 OF 1